

MECHANICAL ENGINEERING Paper I**Time Allowed: Three Hours****Maximum Marks: 200****INSTRUCTIONS**

Please read each of the following instructions carefully before attempting questions.

Candidates should attempt **FIVE** questions in all. Question No, 1 is compulsory.

Out of the remaining **SIX** questions attempt any **FOUR** questions.

The number of marks carried by a part of a question are indicated against it.

Answers must be written in **ENGLISH** only.

Assume suitable data, if necessary, and indicate the same clearly.

For air $R = 0.287 \text{ kJ/kg-K}$, $C_p = 1.005 \text{ kJ/kg-K}$, $\gamma = 1.4$, $M = 28.97 \text{ kg/kg-mole}$,
Universal gas constant $R = 8.314 \text{ kJ/kg mole-K}$.

Unless otherwise mentioned, symbols and notations have their usual standard meanings.

Neat sketches may be drawn, wherever required.

Attempts of questions shall be counted in chronological order. Unless struck off, attempt of a question shall be counted even if attempted partly.

Any page or portion of the page left blank in the answer book must be clearly struck off.

A psychrometric chart is attached to this question paper for necessary use by the candidate.

1. (a) A rigid tank of 0.566 m^3 volume contains air at 6.895 bar and 21.1°C . The tank is equipped with a relief valve that opens at a pressure of 8.618 bar and remains open until the pressure drops to 8.274 bar. If a fire causes the valve to operate once as described, determine the air temperature just before the valve opens and the mass of air lost due to the fire. Assume that the temperature of the air remains constant during discharge and air in the tank behaves as an ideal gas. 20
- (b) A scales are so chosen that a reversible cycle plots clockwise as a circle on the T-S plane. The minimum and maximum values of the temperature are 305 and 627 K and the entropy 1.23 and 2.85 kJ/K, respectively. Find the cycle work and efficiency. 20
2. (a) What is Boiler efficiency and equivalent evaporation of boiler? 20
- (b) In a steam Rankine cycle using one stage of reheating between two turbine cylinders the steam at inlet to HP turbine is at 100 bar and 500°C . The steam at exit of LP turbine is at 0.07 bar and its quality is 85%. The net work output neglecting pump work is 1600 kJ/kg. Determine the cycle thermal efficiency. 20
3. (a) Explain the variation of pressure and velocity of steam in flow-direction in a velocity compounded steam turbine giving sketches. 20
- (b) Steam at 49 N/cm^2 and 160°C is supplied to a single stage impulse turbine at the rate of 30 kg/min, from where it is exhausted to a condenser at a pressure of 1.96 N/cm^2 . The blade speed is 300 m/sec. The nozzles are inclined at 25° to the plane of the wheel and the outlet blade angle is 35° . Neglect friction losses and estimate (i) the theoretical power developed by the turbine; (ii) the diagram efficiency and; (iii) the stage efficiency. 20
4. The compressor of a refrigeration plant having stroke Volume of 500 c.c. runs at 500 r.p.m and works with CO_2 gas. The evaporator and condenser temperatures are -15°C and 25°C respectively. The liquid in the condenser (using another Fr-12 refrigerating system) is under-cooled to 15°C , before passing on to the expansion valve. Assume isentropic compression with an initial quality of CO_2 as $x = 1$ and volumetric efficiency of the compressor as 0.85. Draw a T-S diagram and calculate the following with the help of the tabulated data for saturated CO_2 —

(a) C.O.P.

(b) Power required by compressor assuming motor efficiency to be 0.9.

(c) Actual tonnage capacity of the compressor.

t (C)	h (kJ/kg)	v (m^3/kg)	s (kJ/kg-C)	P (bar)
-------	-----------	------------------------------	-------------	---------

	liq.	vap.	liq.	vap.	liq.	vap.	
-15	49.62	322.86	0.0010	0.0166	0.1976	0.2567	22.88
15	127.75	308.08	0.0013	0.0063	0.4697	1.0959	50.92
25	164.17	283.63	0.0015	0.0015	0.5903	0.9912	64.32

(Specific heat of vapor $\text{CO}_2 = 2.4 \text{ kJ/kg C}$)

40

5. (a) Explain, giving suitable sketches, the working principle of a four-stroke, spark-ignition engine along with valve timing diagram and ignition system. 20
- (b) A gas turbine set takes in air at 27°C and 1 atm. The pressure ratio is 4 and the maximum temperature is 560°C . The compressor and turbine efficiencies are 0.83 and 0.85 respectively. Determine the overall efficiency if the regenerator effectiveness is 0.75. 20
6. (a) Two reservoirs have a difference of water levels of 6 m. They are connected by a pipe system which consists of a single pipe of 60 cm diameter for the first 3000 m and then two pipes in parallel, each of 30 cm in diameter and 3000 m long. Its friction factor, $f = 0.04$, calculate the volume rate of flow of water from the higher reservoirs to the lower reservoirs. 20
- (b) A vertical tapering pipe is 2.3 m long. The diameter of the pipe is 10 cm at the top end and 5 cm at the bottom end. If 25 liters/sec of water flows down through the pipe, find the difference in pressure between the two ends of the pipe. Neglect losses. 20
7. (a) Moist air is heated by steam condensing inside the tubes of a heating coil as shown by Figure. Part of the air passes through the coil and part is by-passed around the coil. Barometric pressure is 1 bar.

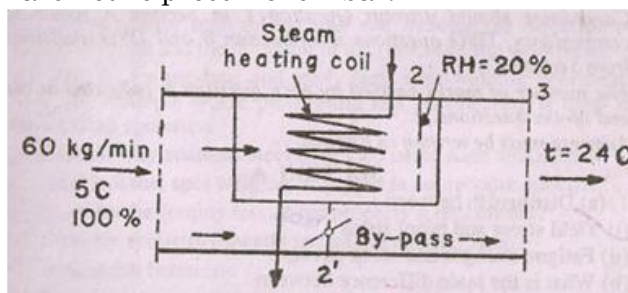

Determine:

- (i) the air per min (in 2) which by-pass the coil and 20
- (ii) the heat added by the coil. 20
- (b) In the design of heat exchanger for aircraft application, the maximum wall temperature in steady state is not to exceed 800 K. For the conditions tabulated below, determine the maximum permissible unit thermal resistance per square meter of the metal wall between hot gas on the one side and cold gas on the other. Hot gas temperature = $T_c = 1300 \text{ K}$, Unit surface conductance on hot side = $h_1 = 200 \text{ W/m}^2 \text{ K}$, Unit surface conductance on cold side = $h_3 = 400 \text{ W/m}^2 \text{ K}$, Coolant temperature = $T_e = 300 \text{ K}$. 20
8. (a) A cold store $7 \text{ m} \times 7 \text{ m} \times 5 \text{ m}$ high has its walls, roof and floor insulated, so as to have the overall heat transfer coefficient of $0.195 \text{ W/m}^2\text{K}$. 200 tons of potatoes are stored at 5°C when the ambient temperature is 35°C . The potatoes are received over a period of six days and are cooled to the storage temperature by a machine working 8 hours a day. The specific heat of potatoes is 4 kJ/kgC . Heat of respiration is 1600 kJ/ton day at 5°C and 4500 kJ/ton day at 35°C . The change in heat of respiration is linear. Calculate the plant load during the loading period. 20
- (b) Write short notes on any two of the following:
 - (i) Heat pump;
 - (ii) Effect of specific speed on efficiency of water turbine;
 - (iii) Choice of different types of turbines for hydroelectric power stations. 20

MECHANICAL ENGINEERING Paper II**Time Allowed: Three Hours****Maximum Marks: 200****INSTRUCTIONS**

Please read each of the following instructions carefully before attempting questions: Candidate should attempt **FIVE** questions in all. Question No. 1 in Section A is compulsory.

Out of the remaining, attempt **TWO** from Section-B and **TWO** from Section—C.

All questions carry equal marks. The number of marks carried by a part of a question is indicated against it.

Answer must be written in **ENGLISH** only.

Unless other-wise mentioned, symbols and notations have their usual standard meanings.

Neat sketches may be drawn, wherever required.

All parts and sub-parts of a question are to be attempted together in the answer book.

Attempts of questions shall be counted in chronological order. Unless struck off, attempt of a question shall be counted even if attempted partly.

Any page or portion of the page left blank in the answer book must be clearly struck off.

SECTION—A

1. Answer all 20 parts of the question each part carries 2 marks.

- (a) Distinguish between:
 - (i) Yield stress and proof stress
 - (ii) Fatigue strength and creep strength.
- (b) What is the main difference between:
 - (i) British standard Whitworth screw threads;
 - (ii) American national screw threads;
 - (iii) Unified screw threads;
 - (iv) Acme screw threads?
- (c) Describe the functions and applications of knuckle and cotter joints.
- (d) Under what conditions is the gear drive preferred over belt drive?
- (e) Distinguish between:
 - (i) Drilling and boring
 - (ii) Planning and shaping
- (f) Explain why and where the shear is provided in a punching operation.
- (g) Explain the use of 'Half Nut' in the operation performed by the Lathe machine.
- (h) What methods are used for changing the direction of rotation?
- (i) Explain the use of nodular cast iron in engineering industry and how is nodular cast iron manufactured?
- (j) Explain the functions of:
 - (i) Fly wheel
 - (ii) Governor
- (k) Give the main reasons for choosing involute profile for a gear tooth.
- (l) Show the distribution of punch pressure and travel in a shearing operation with—
 - (i) insufficient clearance between punch and die;
 - (ii) clearance between punch and die equal to the thickness of the plate.
- (m) Explain the origin and application of 'THERBLIGS'.
- (n) Sketch a three-high rolling mill and indicate the direction of rotation of rolls and the direction of movement of the workpiece.
- (o) Why do we pre-heat and apply heat after welding operation? Give one example where pre-heating and post-heating is done in the welding operation.
- (p) Explain why stainless steel is welded using inert atmosphere.
- (q) Why is it that spot welding of copper is not recommended?
- (r) Describe the Jominy test. What property it determines?
- (s) What are refractory metals and where are they used?
- (t) Distinguish between:
 - (i) Plug gauges

(ii) Snap gauges

SECTION—B

2. (a) The speed ratio of the reverted gear train shown in Fig. 1 is to be 12. The module pitch of gears A and B is 31.25 mm and of gears C and D is 2.5 mm. Calculate the suitable numbers of teeth for the gears. No gear is to have less than 24 teeth. 15

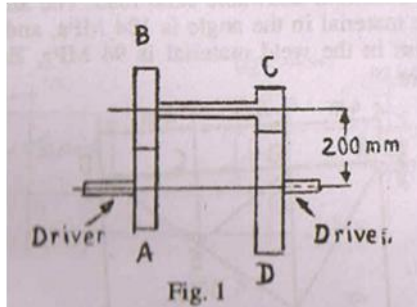

15

- (b) A watt governor has an arm of uniform section of length L and mass m and a ball of mass M. Show that when revolving with angular velocity ω , it makes an angle θ to the vertical, where

$$\cos \theta = \frac{g \left(M + \frac{m}{2} \right)}{\omega^2 L \left(M + \frac{m}{3} \right)}$$

Also determine the angle θ for the case when bar is not of uniform cross-section, its radius of gyration about the point of attachment being k and distance of CG to the point of attachment being d. 25

3. (a) An L 200 × 150 × 20 steel angle is to be welded to a flat plate with the long side of the angle against the plate as shown in Fig. 2

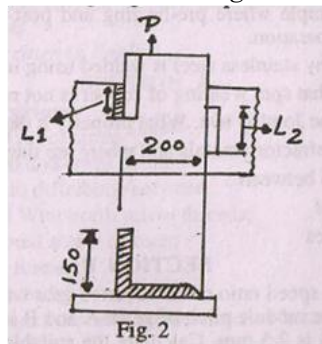

Determine the minimum lengths L_1 and L_2 that will cause the angle to carry the maximum allowable axial load. The allowable tensile stress for the material in the angle is 124 MPa, and the allowable shearing stress in the weld material is 94 MPa. Each leg of the weld is 15 mm. 25

- (b) The crane structure shown in Fig. 3. Supports a car of mass 1800 kg. If member AB is a steel bar 15 mm in diameter (i) determine the force transmitted by member AB; (ii) determine the axial stress in member AB.

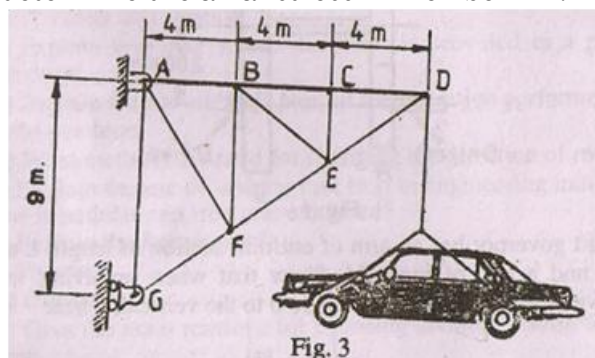

Fig. 3

15

4. (a) At a given point in a machine element, the following stresses were evaluated: 100 MPa T and zero shear on a horizontal plane and 50MPa C on a plane perpendicular to this plane. (Fig. 4). Determine the stresses at this point on a plane having a slope of 3 vertical to 4 horizontal.

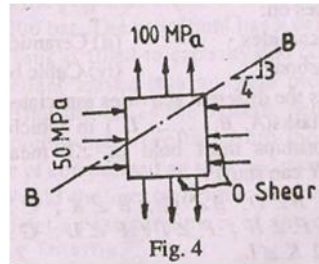

Fig. 4

15

- (b) The steel shaft of Fig. 5 is in equilibrium under the torques shown.

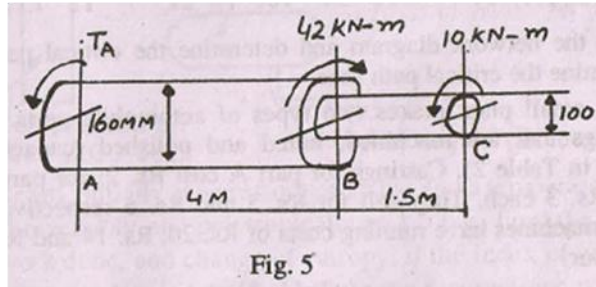

Fig. 5

Determine—

- (i) the maximum shearing stress in the shaft;
- (ii) the angle of twist of end B of the 160 mm segment with respect to end A;
- (iii) the angle of twist of the end C with respect to end A.

The modulus of rigidity is 80 GPa.

25

SECTION—C

5. (a) Draw the three orthographic views of a single point lathe tool and indicate the five tool angles. 10
- (b) Explain the cutting action of the tool in the turning process. 10
- (c) What is meant by 'tool life' and how is tool life affected by cutting speed? 10
- (d) Make a sketch of a quick return mechanism of a shaper and show the velocity distribution. 10

6. (a) Describe the method of hardening of a 0.8% carbon steel with the help of phase and TTT diagrams. 20
- (b) Write short notes on:
 - (i) Cemented carbides (ii) Ceramics (iii) Fluorocarbons (iv) Cubic boron nitride20

7. (a) Table 1 gives the different activities associated with a project consisting of 12 tasks(A, B,....., L) in which the following precedence relationships must hold (X, ∠Y means X must be completed before Y can start): A∠C; A ∠B; B∠D; B∠G; B ∠K; C ∠D; C ∠G; D ∠E ; E ∠F; F ∠H ; F ∠I; F ∠L; G ∠I; G ∠L ; H∠J; I∠J and K ∠L.

Table 1

Task	A	B	C	D	E	F	G	H	I	J	K	L
Time (days)	30	7	10	14	10	7	21	7	12	15	30	15

Draw the network diagram and determine the critical path. Also determine the critical path time. 20

- (b) A small plant makes two types of automobile parts. It buys castings that are machined, bored and polished (capacities are given in Table 2). Castings for part A cost Rs. 2; for part B they cost Rs. 3 each. They sell for Rs. 5 and Rs.6 respectively. The three machines have running costs of Rs. 20, Rs. 14 and Rs. 17.50 per hour.

Table 2

	Part A	Part B
Machining Capacity	25 per hour	40 per hour
Boring Capacity	28 per hour	35 per hour
Polishing Capacity	35 per hour	25 per hour

Assuming that any combination of parts A and B can be sold, what product mix maximizes profit?

20